

TREVIL

Finishing systems



Easyform TOP

Easyform TOP



- Height adjustable cuff clamp.
- Pinza maniche regolabile in altezza e inclinazione.
- Pincas manches réglables en hauteur et inclinaison.
- Ärmelspannern mit Höhen- u. Neigungseinstellung.
- Tensores de mangas con regulación de altura y de inclinación.

- Intuitive electronic control board, can store up to 10 frequently used programs.
- Programmatore elettronico facile da usare, può memorizzare fino a 10 programmi di uso frequente.
- Le programmeur électronique est facile à utiliser et peut mémoriser jusqu'à 10 programmes d'utilisation fréquente.
- Elektronisches Programmiergerät, das einfach und leicht zu bedienen ist und das Speichern der 10 häufigsten Bügelprogramme ermöglicht.
- Programador electrónico, fácil de utilizar, puede memorizar hasta 10 programas de uso frecuente.



- Sleeve expanders and vent clamps supplied with the machine
- Tendimaniche e pinze spacchi forniti in dotazione
- Les extenseurs de manches et les pincas fentes sont fournis avec l'appareil.
- Mitgelieferte Ärmelspanner und Schlitzklammern.
- Tensores para mangas y pinzas con abertura que se entregan con el equipo.



- Blowing adjustment conveniently located on machine front.
- Regolazione del soffiaggio in comoda posizione frontale.
- Réglage du soufflage confortable grâce à sa position frontale.
- Regulierung der Gebläsefunktion in nutzerfreundlicher Frontanbringung.
- Ajuste del soplado en una posición frontal cómoda.



- Pivoting console
- Consolle girevole
- Console tournante.
- Drehkonsole
- Consola giratoria.

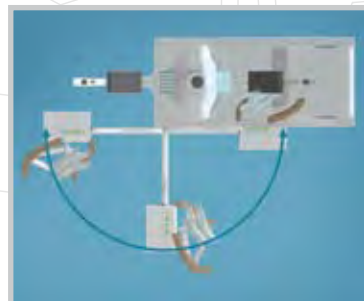

EASYFORM TOP

MODERN Easyform is modern technology applied to a traditional form finisher. Easyform offers features usually found in higher category finishers, such as the automatic sleeve clamps and the electronic control board, that allows to program and store common finishing cycles.

CONVENIENT Easyform is designed for the operator's comfort. The blowing adjustment conveniently located on the front can be shifted with a foot. The pivoting console can be moved to the most convenient position. A single front pedal starts the cycle.

COMPACT Easyform has small footprint of 40 x 120 cm. It is available for connection to central steam or with built-in boiler, either 7,5 kW or 15 kW.

VERSATILE Thanks to the special collar clamp and the cuff clamps, Easyform can finish also shirts and blouses, not only jackets, coats and ladies dresses!

EASYFORM TOP

MODERNO Easyform è l'applicazione dei moderni criteri di costruzione ad un manichino di tipo tradizionale. Ad un prezzo estremamente vantaggioso, Easyform offre caratteristiche normalmente applicate in manichini di categoria superiore come il controllo elettronico dei tempi di stiratura, con possibilità di memorizzare i cicli maggiormente utilizzati e le pinze maniche a funzionamento automatico.

CONFORTEVOLE Easyform è studiato per offrire una postazione di lavoro comoda. La leva di regolazione del soffiaggio in posizione frontale può essere azionata comodamente con un piede. La consolle di comando è girevole per essere posizionata nel punto più comodo all'operatore. Il ciclo viene avviato tramite un unico pedale frontale.

COMPATTO Easyform occupa uno spazio a terra di soli 40 x 120 cm ed è disponibile anche nella versione con caldaia incorporata da 7,5 kW o da 15 kW.

VERSATILE Con la speciale pala fermacollo e le pinze tendimanica, Easyform è in grado di stirare anche camicie e camicette da donna, non solo giacche, giubbotti e vestiti da donna!

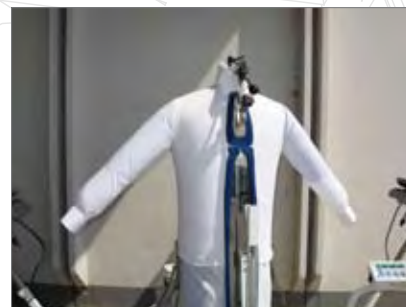
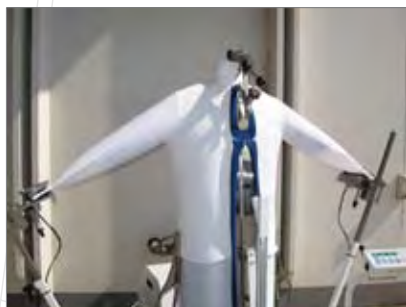



| DATI TECNICI | TECHNICAL SPECIFICATIONS | DONNEES TECHNIQUES | TECHNISCHE DATEN | DATOS TÉCNICOS | 5058 | 5059 |
|---|---|--|---|--|--|--|
| Alimentazione elettrica | Electrical requirements | Entrée courant | Stromversorgung | Alimentación eléctrica | 400V 50Hz 3phase 220V 60Hz 3phase * | 400V 50Hz 3phase 220V 60Hz 3phase * |
| Potenza nominale | Power consumption | Puissance nominale | Nennleistung | Potencia nominal | 1,2 kW | 17 kW |
| . soffiaggio | . blowing | . soufflage | . Leistung Absauger | . Potencia soplado | 1,1 kW 1.5HP | 1,1 kW 1.5HP |
| . caldaia | . boiler | . chaudière | . Widerstand Kessel | . Resistencia caldera | - | 15 kW |
| . pompa | . pump | . pompe | . pumpe | . bomba | - | 800 W |
| Entrata vapore | Steam inlet | Entrée vapeur | Dampfeinlass | Entrada vapor | 6 1/2" | - |
| Uscita condensa | Condensate outlet | Retour d'eau condensée | Kondensatrückführung | Retorno condensado | 6 1/2" | - |
| Consumo vapore | Steam consumption | Consommation vapeur | Dampfverbrauch | Consumo de vapor | 15-20 kg/h | - |
| Pressione vapore | Steam pressure | Pression vapeur | Dampfdruck | Presión vapor | 600kPa 6bar 72PSI | - |
| Attacco acqua | Water inlet | Alimentation eau | Wasseranschluss | Acometida agua | - | ø 16 mm |
| Scarico caldaia | Boiler exhaust | Décharge chaudière | Kesselablass | Desagüe caldera | - | 6 1/2" |
| Aia compressa per modello con pinze maniche | Compressed air for model with sleeve clamps | Air comprimé pour modèle avec pinces manches | Pressluft für Modell mit Ärmelklammern. | Aire comprimido para modelo con pinza para mangas. | | |
| . pressione aria | . air pressure | . pression d'air comprimé | . Druckluftdruck | . Presión aire | 600kPa 6bar 72PSI | 600kPa 6bar 72PSI |
| . attacco aria | . air inlet | . entrée air | . Lufteinlass | . Entrada aire | 1/4" | 1/4" |
| . consumo aria | . air consumption | . consommation d'air | . Luftverbrauch | . Consumo de aire | 5 NI/min | 5 NI/min |

* Altri a richiesta

*Others available

*Autres sur demande

*Andere auf Anfrage

*Otros por petición

Con rise va di modifica senza preavviso - Subject to modification without notice - Sous réserve de modification sans préavis - Änderungen vorbehalten - Con reserva de modificación sin previo aviso

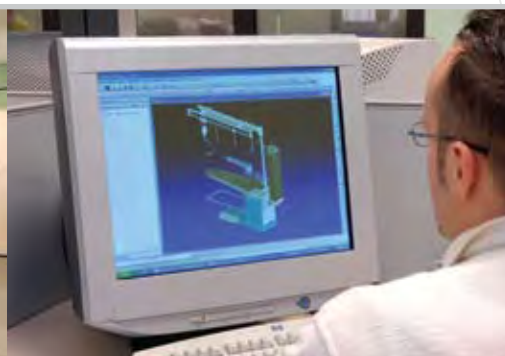
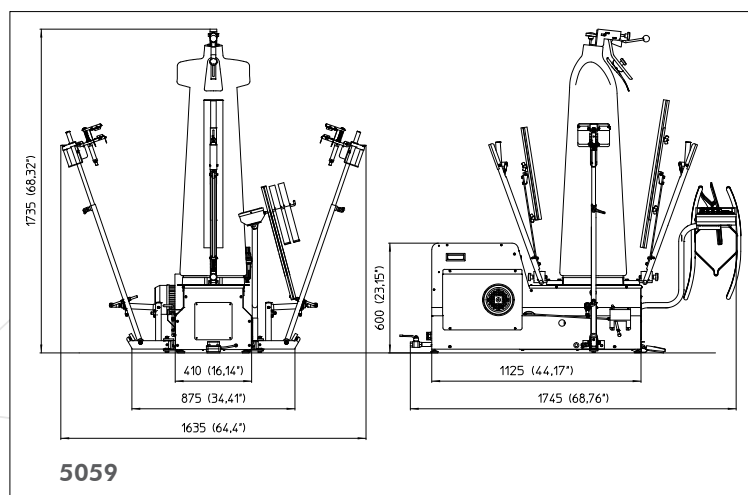
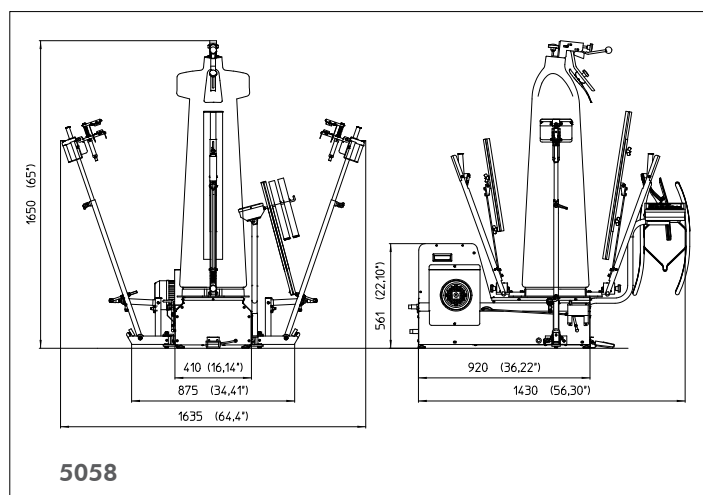

TREVIL

Trevil srl Via Copernico 1 20060 Pozzo d'Adda (MI) Italy - Tel +39 02 9093141 Fax +39 02 90968202
 www.trevil.com - info@trevil.com